

parts catalog

FORCE SERIES

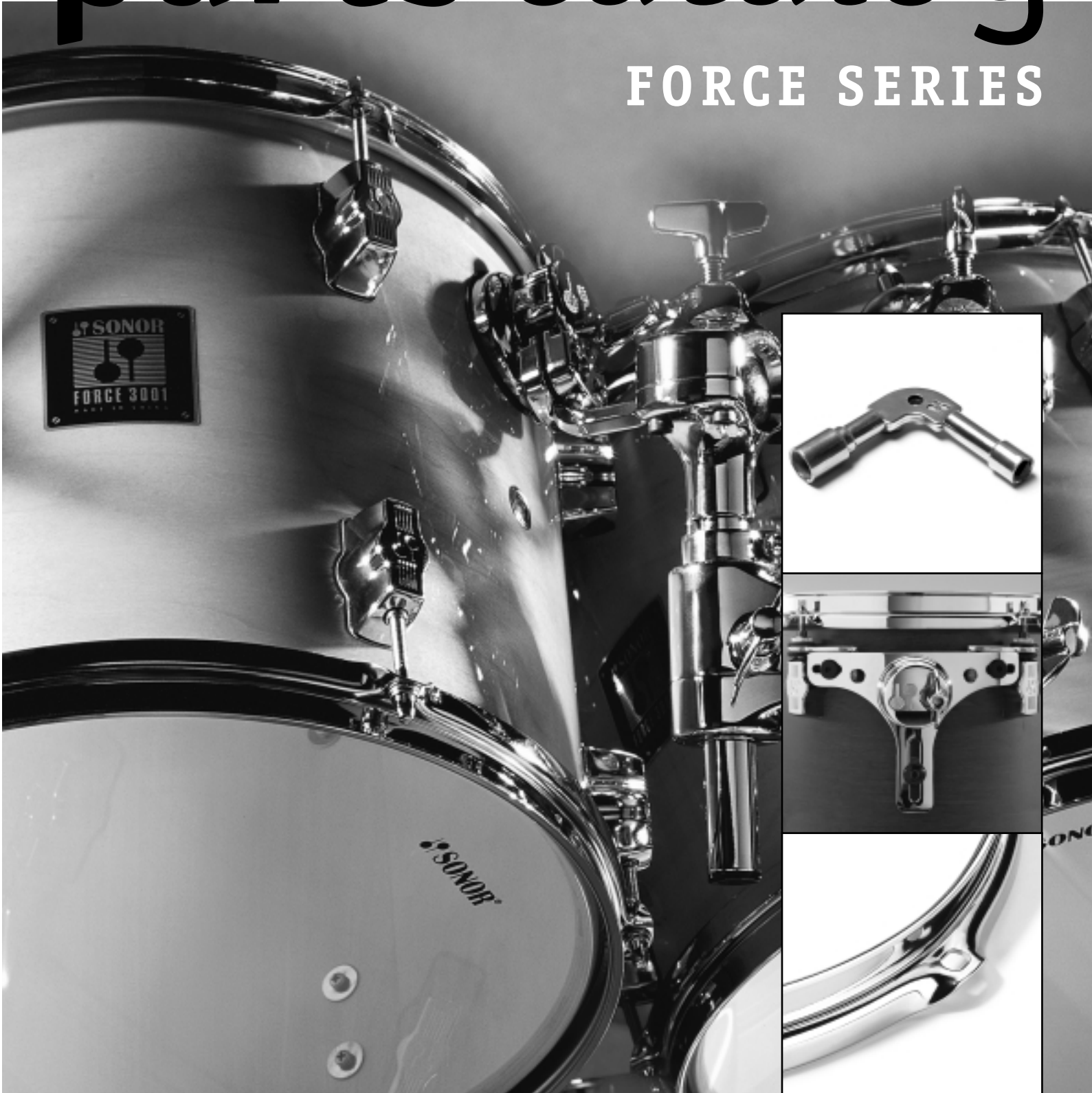

200 SERIES HARDWARE

HH 224 HI HAT STAND

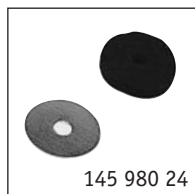
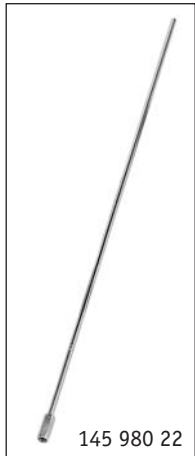
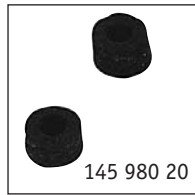

Item number	Description	Price
① 145 981 19	Top Cymbal Holder (clutch), complete	<input type="text"/>
② 145 980 20	Felt Washer for Top Cymbal Holder, 25mm dia., 2 pcs/pack	<input type="text"/>
③ 145 981 21	Wing Screw M6x10 for Top Cymbal Holder, 3pcs/pack	<input type="text"/>
④ 145 980 22	Top Pull Rod	<input type="text"/>
⑤ 145 980 18	Top Tube, with Fix Clamp	<input type="text"/>
⑥ 145 980 24	Felt Washer for Bottom Cymbal Holder + 1 pc Metal Washer, 50mm dia., 3 sets/pack	<input type="text"/>
⑦ 145 980 09	Wing Screw M8 x 18, 3pcs/pack	<input type="text"/>
⑧ 145 980 26	Foot Board with Heel Plate and Chain (Giant Step Design)	<input type="text"/>
⑨ 145 980 05	Rubber Foot, 3 pcs/pack	<input type="text"/>
⑩ 145 980 28	Knurled Screw with Spur, Spring and Washer, complete set, 3 sets/pack	<input type="text"/>
⑪ 145 980 67	Strut (only for Giant Step Design)	<input type="text"/>
⑫ 145 980 66	Connecting Plate for Struts, with Screws (only for Giant Step Design)	<input type="text"/>

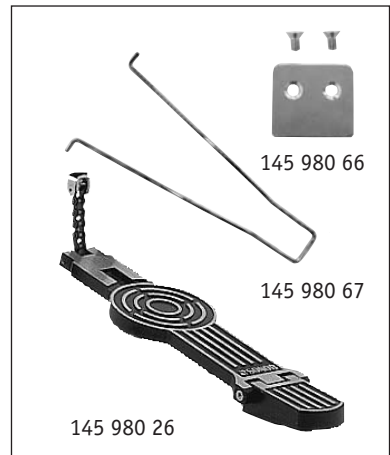

400 SERIES HARDWARE

HH 444 HI HAT STAND

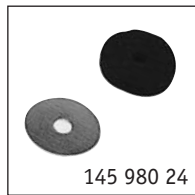
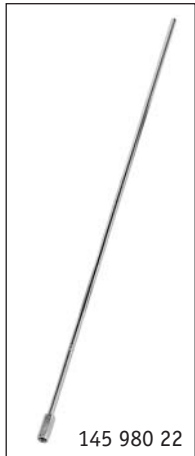
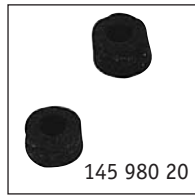

Item number	Description	Price
① 145 981 19	Top Cymbal Holder (clutch) complete	<input type="text"/>
② 145 980 20	Felt Washer for Top Cymbal Holder, 25mm dia., 2 pcs/pack	<input type="text"/>
③ 145 981 21	Wing Screw M6x10 for Top Cymbal Holder, 3pcs/pack	<input type="text"/>
④ 145 980 22	Top Pull Rod	<input type="text"/>
⑤ 145 981 45	Top Tube, with Fix Clamp	<input type="text"/>
⑥ 145 980 24	Felt Washer for Bottom Cymbal Holder + 1 pc Metal Washer, 50mm dia., 3 sets/pack	<input type="text"/>
⑦ 145 980 09	Wing Screw M8 x 18, 3pcs/pack	<input type="text"/>
⑧ 145 980 52	Fix Clamp with Square Head Screw, 19mm dia., 2 pcs/pack	<input type="text"/>
⑨ 145 980 26	Foot Board with Heel Plate and Chain (Giant Step Design)	<input type="text"/>
⑩ 145 980 05	Rubber Foot, 3 pcs/pack	<input type="text"/>
⑪ 145 980 28	Knurled Screw with Spur, Spring and Washer, complete set, 3 sets/pack	<input type="text"/>
⑫ 145 980 67	Strut (only for Giant Step Design)	<input type="text"/>
⑬ 145 980 66	Connecting Plate for Struts, with Screws (only for Giant Step Design)	<input type="text"/>
⑭ 145 941 75	Toe Stop, complete	<input type="text"/>

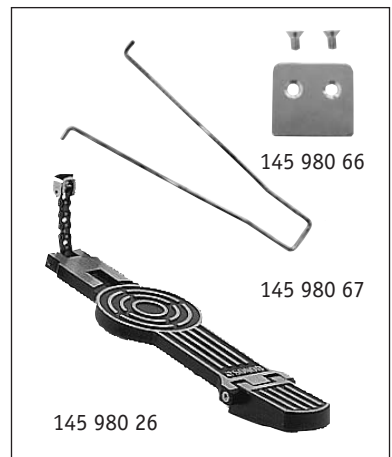

200 SERIES HARDWARE

SS 227 SNARE DRUM STAND

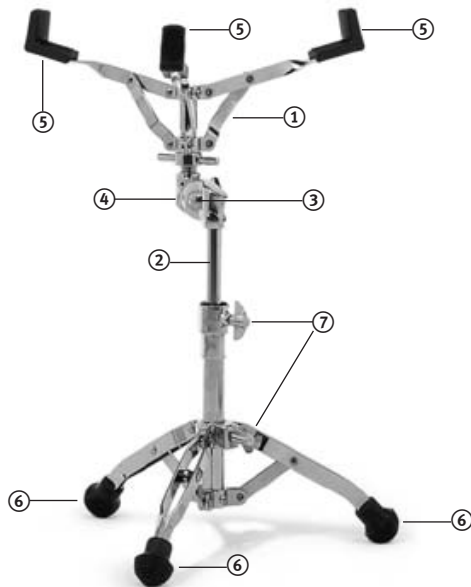
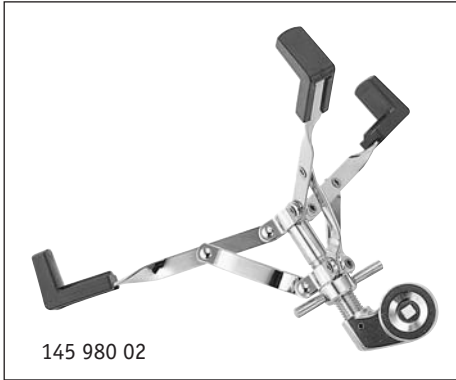

Item number	Description	Price
① 145 980 02	Top Basket, without Tube	<input type="text"/>
② 145 980 04	Middle Tube	<input type="text"/>
③ 145 980 45	Wing Nut M8, with Washer, 3 pcs/pack	<input type="text"/>
④ 145 980 51	Flat Round Screw M8 x 50, incl. Washer, Spring and Wing Nut, 2 sets/pack	<input type="text"/>
⑤ 145 980 62	Rubber Rest for Basket, 3 pcs/pack	<input type="text"/>
⑥ 145 980 05	Rubber Foot, 3 pcs/pack	<input type="text"/>
⑦ 145 980 09	Wing Screw M8 x 18, 3 pcs/pack	<input type="text"/>

400 SERIES HARDWARE

SS 447 SNARE DRUM STAND

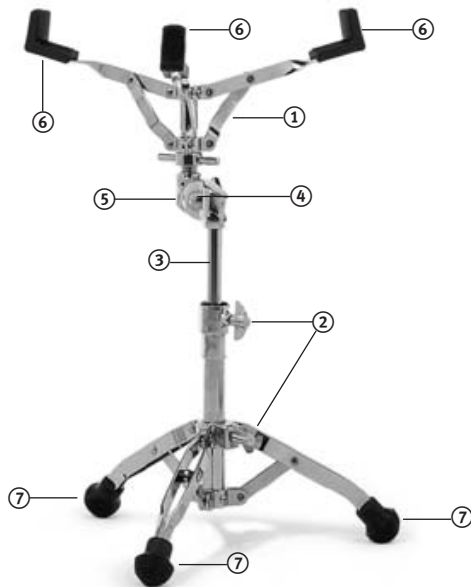
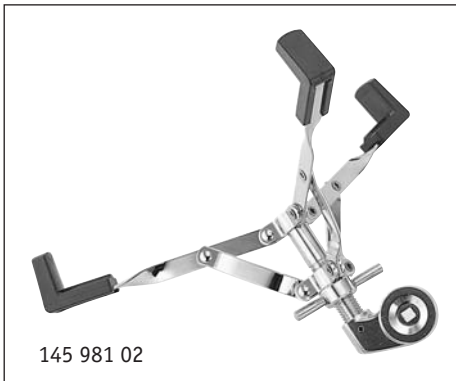

Item number	Description	Price
① 145 981 02	Top Basket, without Tube	<input type="text"/>
② 145 980 09	Wing Screw M8 x 18, 3 pcs/pack	<input type="text"/>
③ 145 981 04	Middle Tube	<input type="text"/>
④ 145 980 45	Wing Nut M8, with Washer, 3 pcs/pack	<input type="text"/>
⑤ 145 980 51	Flat Round Screw M8 x 50, incl. Washer, Spring and Wing Nut, 2 sets/pack	<input type="text"/>
⑥ 145 980 62	Rubber Rest for Basket, 3 pcs/pack	<input type="text"/>
⑦ 145 980 05	Rubber Foot, 3 pcs/pack	<input type="text"/>

200 SERIES HARDWARE

CS 220 CYMBAL STAND

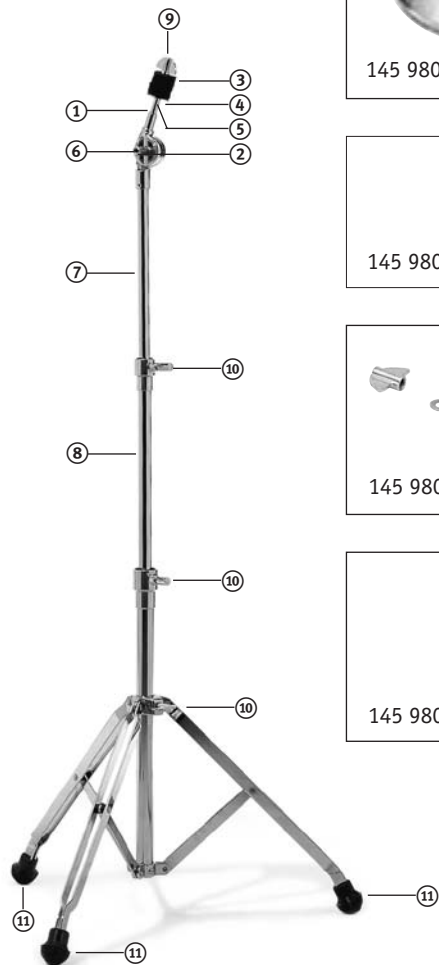
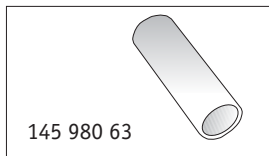
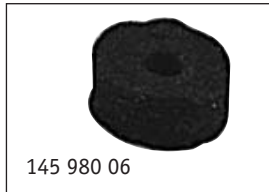

Item number	Description	Price
① 145 980 08	Top Cymbal Holder (Tilter), complete	<input type="text"/>
② 145 980 45	Wing Nut M8, with Washer, 3 pcs/pack	<input type="text"/>
③ 145 980 06	Felt Washer, 4 pcs/pack	<input type="text"/>
④ 145 980 07	Metal Washer for Tilter, 35mm dia., 2 pcs/pack	<input type="text"/>
⑤ 145 980 63	Bushing, 6 pcs/pack	<input type="text"/>
⑥ 145 980 51	Flat Round Screw M8 x 50, complete with Washer, Spring and Wing Nut, 2 pcs/pack	<input type="text"/>
⑦ 145 980 16	Top Tube	<input type="text"/>
⑧ 145 980 15	Middle Tube	<input type="text"/>
⑨ 145 980 44	Wing Nut M6, 3 pcs/pack	<input type="text"/>
⑩ 145 980 09	Wing Screw M8 x 18, 3 pcs/pack	<input type="text"/>
⑪ 145 980 05	Rubber Foot, 3 pcs/pack	<input type="text"/>

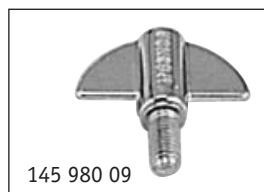
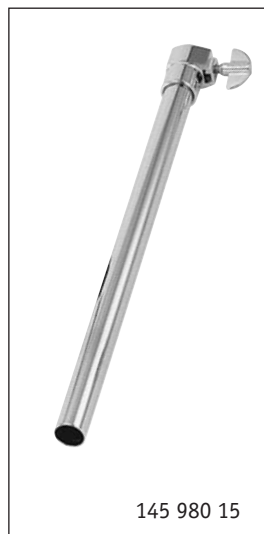

400 SERIES HARDWARE

CS 440 CYMBAL STAND

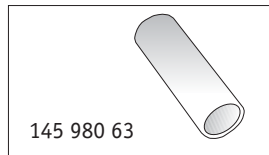
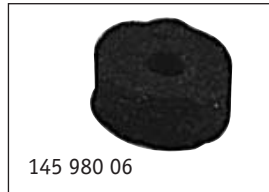

Item number	Description	Price
① 145 980 08	Top Cymbal Holder (Tilter), complete	<input type="text"/>
② 145 980 45	Wing Nut M8, with Washer, 3 pcs/pack	<input type="text"/>
③ 145 980 06	Felt Washer, 4 pcs/pack	<input type="text"/>
④ 145 980 07	Metal Washer for Tilter, 35mm dia., 2 pcs/pack	<input type="text"/>
⑤ 145 980 63	Bushing, 6 pcs/pack	<input type="text"/>
⑥ 145 980 51	Flat Round Screw M8 x 50, complete with Washer, Spring and Wing Nut, 2 pcs/pack	<input type="text"/>
⑦ 145 980 16	Top Tube	<input type="text"/>
⑧ 145 981 59	Middle Tube	<input type="text"/>
⑨ 145 980 44	Wing Nut M6, 3 pcs/pack	<input type="text"/>
⑩ 145 980 09	Wing Screw M8 x 18, 3 pcs/pack	<input type="text"/>
⑪ 145 980 05	Rubber Foot, 3 pcs/pack	<input type="text"/>

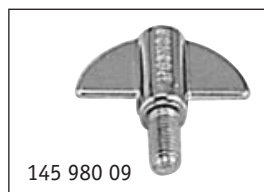
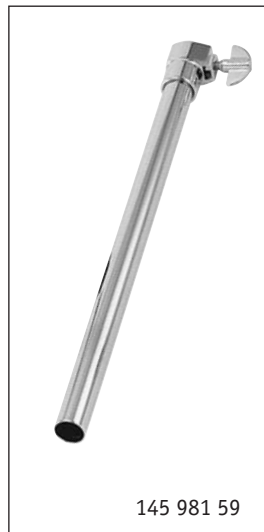
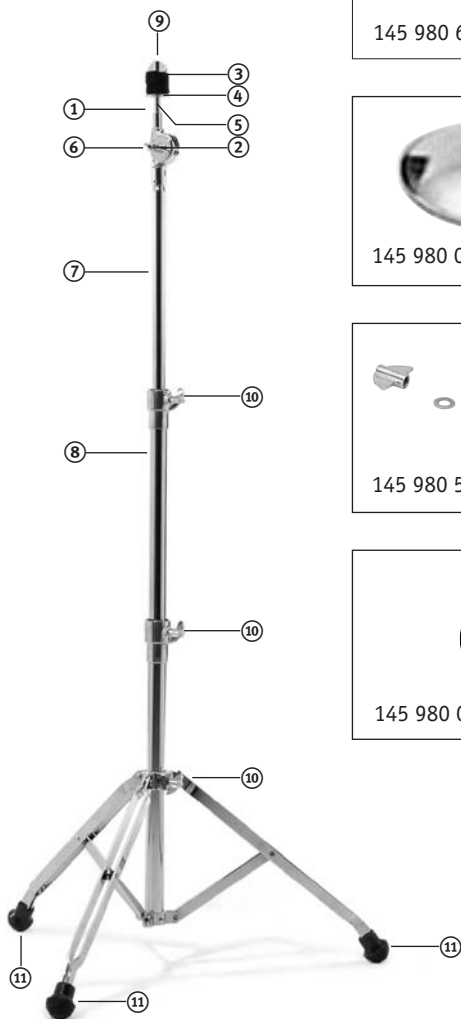

200 SERIES HARDWARE

MBS 223 MINI BOOM CYMBAL STAND

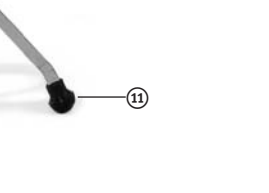
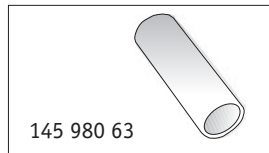
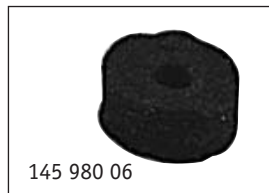

Item number	Description	Price
① 145 980 08	Top Cymbal Holder (Tilter), complete	<input type="text"/>
② 145 980 45	Wing Nut M8, with Washer, 3 pcs/pack	<input type="text"/>
③ 145 980 06	Felt Washer, 4 pcs/pack	<input type="text"/>
④ 145 980 63	Bushing, 6 pcs/pack	<input type="text"/>
⑤ 145 980 07	Metal Washer for Tilter, 35mm dia., 2 pcs/pack	<input type="text"/>
⑥ 145 980 51	Flat Round Screw M8 x 50 with Washer, Spring and Wing Nut, 2pcs/pack	<input type="text"/>
⑦ 145 980 10	Extension Arm 16.5 x 300mm	<input type="text"/>
⑧ 145 980 11	Tube with Adjusting Lock, 19mm dia.	<input type="text"/>
⑨ 145 980 44	Wing Nut M6, 3 pcs/pack	<input type="text"/>
⑩ 145 980 09	Wing Screw M8 x 18, 3 pcs/pack	<input type="text"/>
⑪ 145 980 05	Rubber Foot, 3 pcs/pack	<input type="text"/>

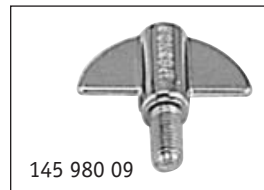

400 SERIES HARDWARE

MBS 443 MINI BOOM CYMBAL STAND

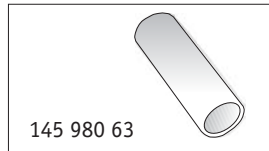
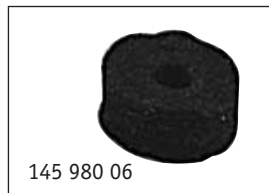

Item number	Description	Price
① 145 980 08	Top Cymbal Holder (Tilter), complete	<input type="text"/>
② 145 980 45	Wing Nut M8, with Washer, 3 pcs/pack	<input type="text"/>
③ 145 980 06	Felt Washer, 4 pcs/pack	<input type="text"/>
④ 145 980 63	Bushing, 6 pcs/pack	<input type="text"/>
⑤ 145 980 07	Metal Washer for Tilter, 35mm dia., 2 pcs/pack	<input type="text"/>
⑥ 145 980 51	Flat Round Screw M8 x 50 with Washer, Spring and Wing Nut, 2 pcs/pack	<input type="text"/>
⑦ 145 980 10	Extension Arm 16.5 x 300mm	<input type="text"/>
⑧ 145 981 17	Tube with Adjusting Lock, 19mm dia.,	<input type="text"/>
⑨ 145 980 44	Wing Nut M6, 3 pcs/pack	<input type="text"/>
⑩ 145 980 09	Wing Screw M8 x 18, 3 pcs/pack	<input type="text"/>
⑪ 145 980 05	Rubber Foot, 3 pcs/pack	<input type="text"/>
⑫ 145 981 59	Middle Tube	<input type="text"/>

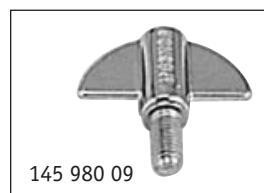

400 SERIES HARDWARE

CBS 442 CYMBAL BOOM STAND

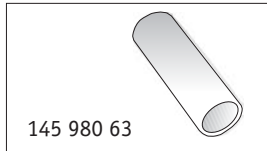
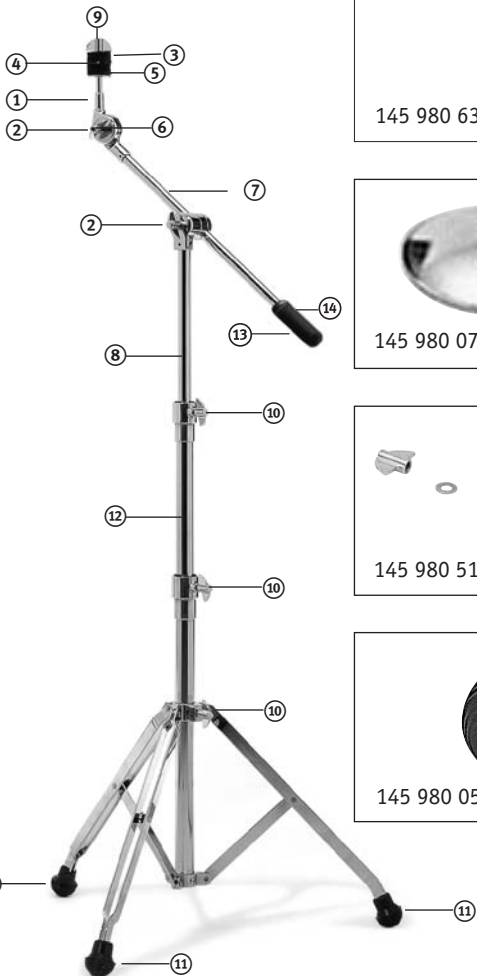
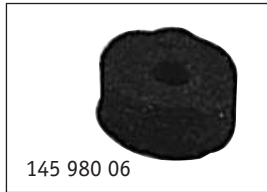

Item number	Description	Price
① 145 980 08	Top Cymbal Holder (Tilter), complete	<input type="text"/>
② 145 980 45	Wing Nut M8, with Washer, 3 pcs/pack	<input type="text"/>
③ 145 980 06	Felt Washer, 4 pcs/pack	<input type="text"/>
④ 145 980 63	Bushing, 6 pcs/pack	<input type="text"/>
⑤ 145 980 07	Metal Washer for Tilter, 35mm dia., 2 pcs/pack	<input type="text"/>
⑥ 145 980 51	Flat Round Screw M8 x 50 with Washer, Spring and Wing Nut, 2 pcs/pack	<input type="text"/>
⑦ 145 980 58	Extension Arm 16.5 x 600mm	<input type="text"/>
⑧ 145 981 17	Tube with Adjusting Lock, 19mm dia.,	<input type="text"/>
⑨ 145 980 44	Wing Nut M6, 3 pcs/pack	<input type="text"/>
⑩ 145 980 09	Wing Screw M8 x 18, 3 pcs/pack	<input type="text"/>
⑪ 145 980 05	Rubber Foot, 3 pcs/pack	<input type="text"/>
⑫ 145 981 59	Middle Tube	<input type="text"/>
⑬ 145 980 59	Counter Weight	<input type="text"/>
⑭ 145 980 60	Grub Screw, 3 pcs/pack	<input type="text"/>

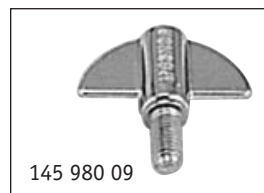
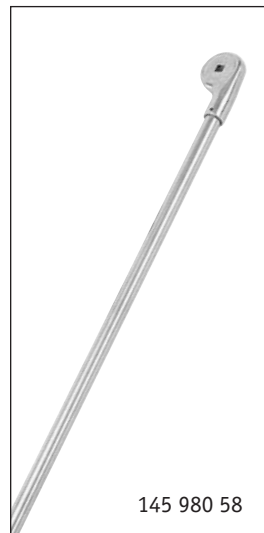

200 SERIES HARDWARE

P 233 BASS DRUM PEDAL

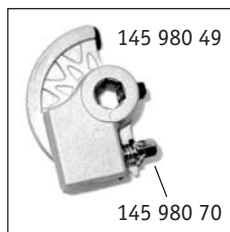
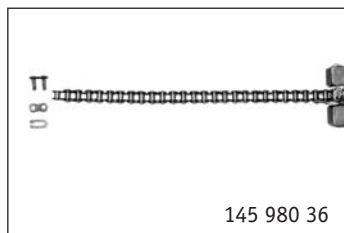
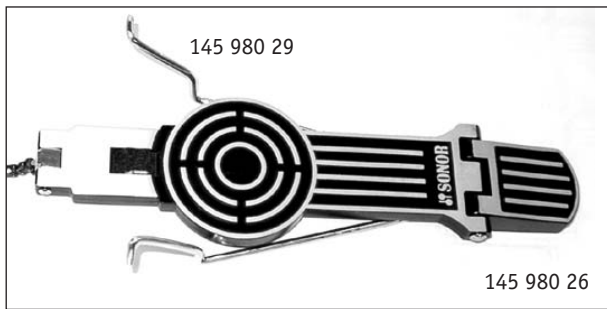
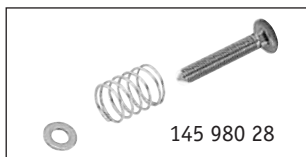

Item number	Description	Price
① 145 980 38	Pedal Axle, with Ball Bearing and Nut M6	<input type="text"/>
② 145 980 69	Wing Screw, for Hoop Clamp, 3 pcs/pack	<input type="text"/>
③ 145 980 35	Main Spring Unit, complete	<input type="text"/>
④ 908 801 00	Pedal Beater	<input type="text"/>
⑤ 145 980 28	Knurled Screw with Spur, Spring and Washer, complete, 3 pcs/pack	<input type="text"/>
⑥ 145 980 29	Strut	<input type="text"/>
⑦ 145 980 30	Hoop Clamp, complete, with Rivet and Screw	<input type="text"/>
⑧ 145 980 65	Spring Connector	<input type="text"/>
⑨ 145 980 49	Beater Cam	<input type="text"/>
⑩ 145 980 36	Chain, with Chain Bearing and Rivet, complete	<input type="text"/>
⑪ 145 980 26	Foot Board, with Heel Plate, Chain and Rivet, complete (Giant Step Design)	<input type="text"/>
⑫ 145 980 66	Connecting Plate, with Screws	<input type="text"/>
⑬ 145 980 70	Square Head Screw, 3 pcs/pack	<input type="text"/>

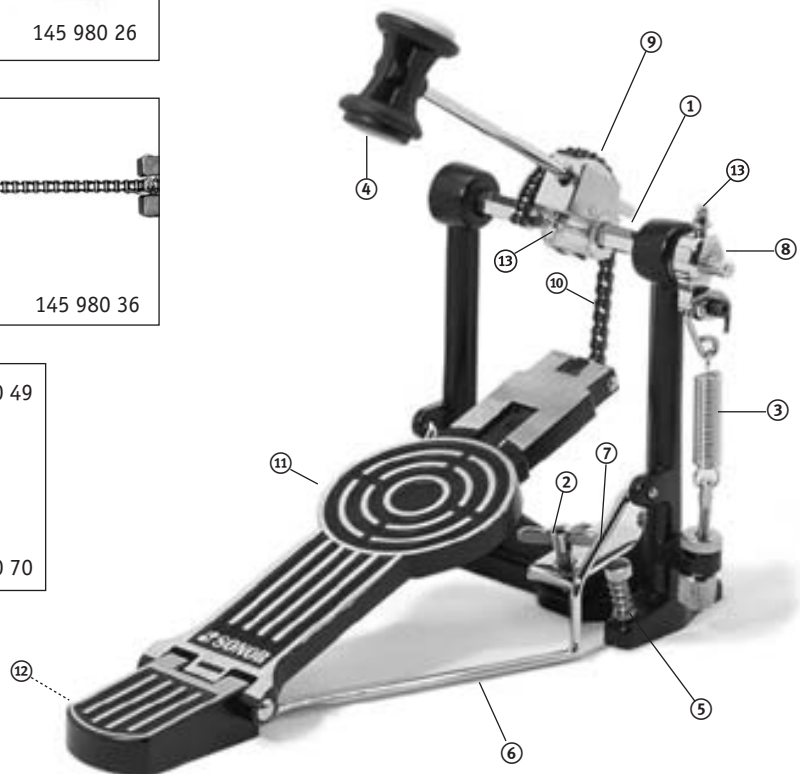

400 SERIES HARDWARE

P 433 BASS DRUM PEDAL

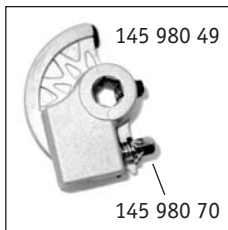
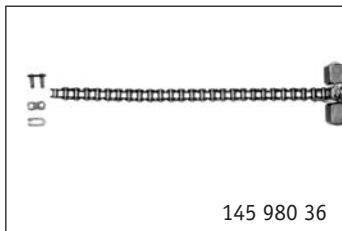
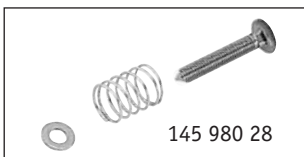

Item number	Description	Price
① 145 980 38	Pedal Axle, with Ball Bearing and Nut M6	<input type="text"/>
② 145 980 69	Wing Screw, for Hoop Clamp, 3 pcs/pack	<input type="text"/>
③ 145 980 35	Main Spring Unit, complete	<input type="text"/>
④ 908 801 00	Pedal Beater	<input type="text"/>
⑤ 145 980 28	Knurled Screw with Spur, Spring and Washer, complete, 3 pcs/pack	<input type="text"/>
⑥ 145 980 71	Bottom Plate, with Screws	<input type="text"/>
⑦ 145 980 30	Hoop Clamp, complete, with Rivet and Screw	<input type="text"/>
⑧ 145 980 65	Spring Connector	<input type="text"/>
⑨ 145 980 49	Beater Cam	<input type="text"/>
⑩ 145 980 36	Chain, with Chain Bearing and Rivet, complete	<input type="text"/>
⑪ 145 980 26	Foot Board, with Heel Plate, Chain and Rivet, complete (Giant Step Design)	<input type="text"/>
⑫ 145 941 75	Toe Stop, complete, with Screw	<input type="text"/>
⑬ 145 980 70	Square Head Screw, 3 pcs/pack	<input type="text"/>

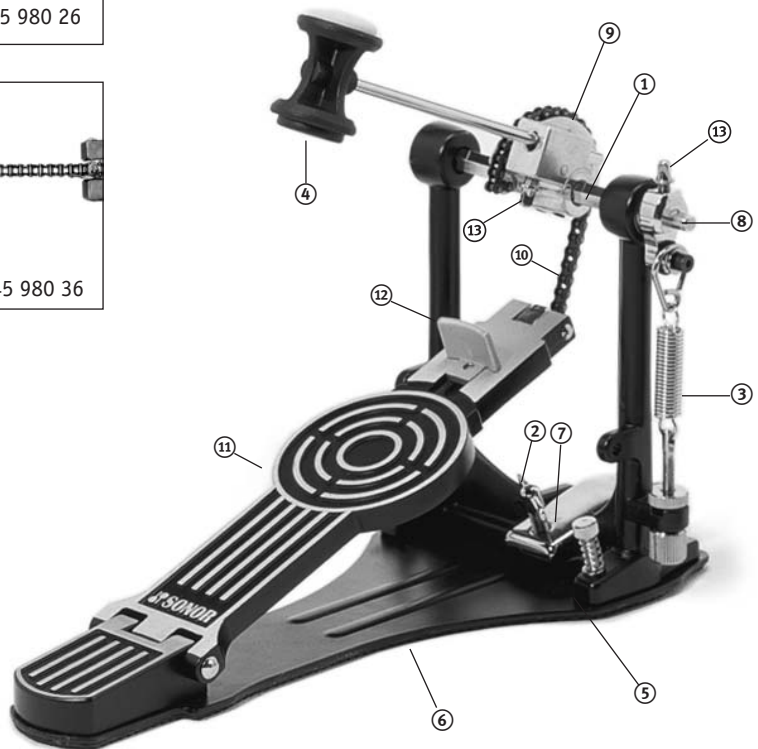

200/400 SERIES HARDWARE

TA 328 TOM ARM



Item number	Description	Price
① 145 016 01	Memory Lock ML 1, complete	<input type="text"/>
② 145 941 52	Fix Clamp, 19mm dia., complete	<input type="text"/>
③ 145 941 80	Wing Screw for Ball Socket Joint, M8 x 25, 2 pcs/pack	<input type="text"/>
④ 145 980 56	Allen Screw M5 x 20, DIN 912, with Washer, 4 sets/pack	<input type="text"/>
⑤ 145 980 55	Ball with Hex Arm and Memory Lock ML 1, complete	<input type="text"/>



400 SERIES HARDWARE

CTS 449 CYMBAL TOM STAND

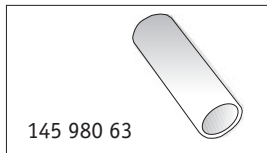
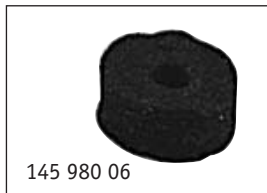

Item number	Description	Price
① 145 980 08	Top Cymbal Holder (Tilter), complete	<input type="text"/>
② 145 980 45	Wing Nut M8 with Washer, 3 pcs/pack	<input type="text"/>
③ 145 980 06	Felt Washer, 4 pcs/pack	<input type="text"/>
④ 145 980 63	Bushing, 6 pcs/pack	<input type="text"/>
⑤ 145 980 07	Metal Washer for Tilter, 35mm dia., 2 pcs/pack	<input type="text"/>
⑥ 145 980 51	Flat Round Screw M8 x 50 with Washer, Spring and Wing Nut, 2 pcs/pack	<input type="text"/>
⑦ 145 980 10	Extension Arm 16.5 x 300mm	<input type="text"/>
⑧ 145 980 11	Tube with Adjusting Lock, 19mm dia.	<input type="text"/>
⑨ 145 980 44	Wing Nut M6, 3 pcs/pack	<input type="text"/>
⑩ 145 308 01	Tom Arm TA 328, complete	<input type="text"/>
⑪ 145 981 60	Tube with Bracket, complete	<input type="text"/>
⑫ 145 980 09	Wing Screw M8 x 18, 3 pcs/pack	<input type="text"/>
⑬ 145 980 05	Rubber Foot, 3 pcs/pack	<input type="text"/>
⑭ 145 941 52	Fix Clamp, 19mm dia., complete	<input type="text"/>
⑮ 145 941 83	Fix Clamp, 25.5mm dia., complete	<input type="text"/>
⑯ 145 016 01	Memory Lock ML1, complete	<input type="text"/>
⑰ 145 941 80	Wing Screw at Ball-on-Socket-Joint M8 x 25, 2 pcs/pack	<input type="text"/>
⑱ 145 980 65	Allen Screw M5 x 20, DIN 912, with Washer, 4 pcs/pack	<input type="text"/>
⑲ 145 980 55	Ball with Hex Arm and Memory Lock ML1, complete	<input type="text"/>

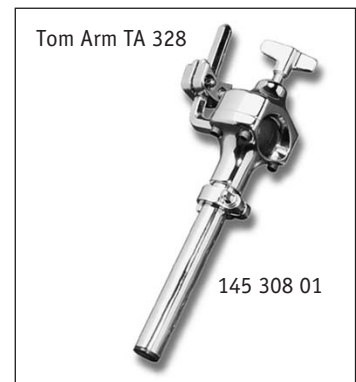

145 329 01 MBA 441 Mini Boom Arm, complete (see separate listing MBA 441)

400 SERIES HARDWARE

DCS 448 DOUBLE CYMBAL STAND

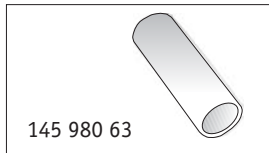
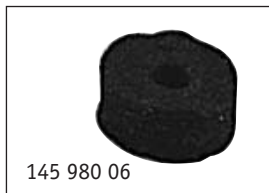

Item number	Description	Price
① 145 980 08	Top Cymbal Holder (Tilter), complete	<input type="text"/>
② 145 980 45	Wing Nut M8 with Washer, 3 pcs/pack	<input type="text"/>
③ 145 980 06	Felt Washer, 4 pcs/pack	<input type="text"/>
④ 145 980 63	Bushing, 6 pcs/pack	<input type="text"/>
⑤ 145 980 07	Metal Washer for Tilter, 35mm dia., 2 pcs/pack	<input type="text"/>
⑥ 145 980 51	Flat Round Screw M8 x 50 with Washer, Spring and Wing Nut, 2 pcs/pack	<input type="text"/>
⑦ 145 980 10	Extension Arm 16.5 x 300mm	<input type="text"/>
⑧ 145 980 11	Tube with Adjusting Lock, 19mm dia.	<input type="text"/>
⑨ 145 980 44	Wing Nut M6, 3 pcs/pack	<input type="text"/>
⑩ 145 329 01	Mini Boom Arm MB 441, complete	<input type="text"/>
⑪ 145 981 60	Tube with Bracket, complete	<input type="text"/>
⑫ 145 980 09	Wing Screw M8 x 18, 3 pcs/pack	<input type="text"/>
⑬ 145 980 05	Rubber Foot, 3 pcs/pack	<input type="text"/>
⑭ 145 941 52	Fix Clamp 19mm dia., complete	<input type="text"/>
⑮ 145 941 83	Fix Clamp 25.5mm dia., complete	<input type="text"/>



400 SERIES HARDWARE

DTS 445 DOUBLE TOM STAND

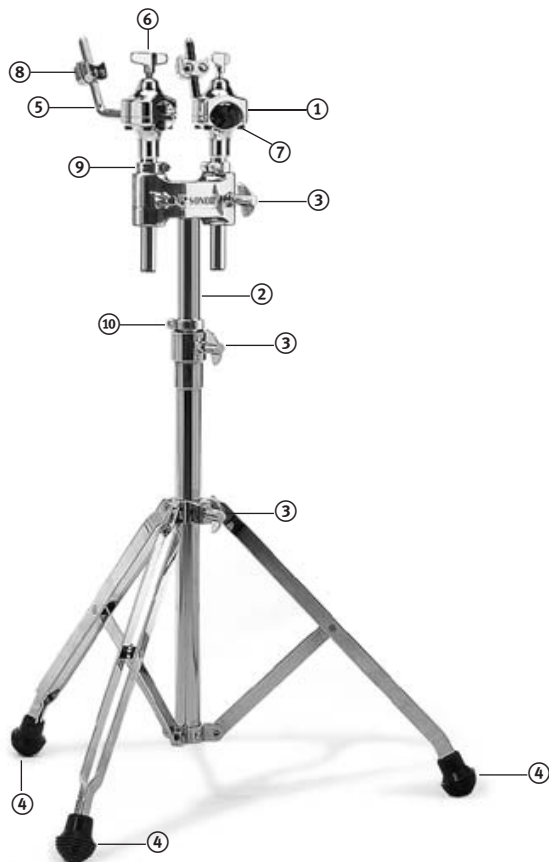

Item number	Description	Price
① 145 308 01	Tom Arm TA 328, complete	<input type="text"/>
② 145 981 60	Tube with Bracket, complete	<input type="text"/>
③ 145 980 09	Wing Screw M8 x 18, 3 pcs/pack	<input type="text"/>
④ 145 980 05	Rubber Foot, 3 pcs/pack	<input type="text"/>
⑤ 145 980 55	Ball with Hex Arm and Memory Lock ML1, complete	<input type="text"/>
⑥ 145 941 80	Wing Screw for Ball Socket Joint, M8 x 25, 2 pcs/pack	<input type="text"/>
⑦ 145 980 56	Allen Screw M5 x 20, DIN 912, with Washer, 4 pcs/pack	<input type="text"/>
⑧ 145 016 01	Memory Lock ML1, complete	<input type="text"/>
⑨ 145 941 52	Fix Clamp, 19mm dia., complete	<input type="text"/>
⑩ 145 941 83	Fix Clamp 25.5mm dia., complete	<input type="text"/>

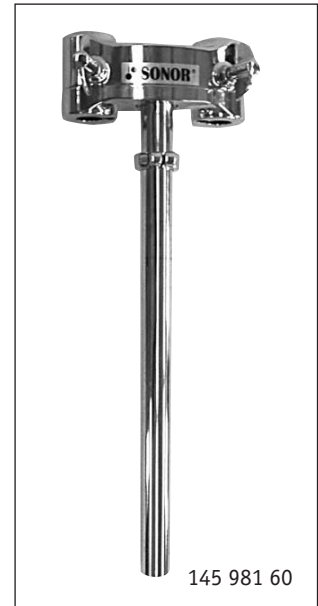

200/400 SERIES HARDWARE

DTH 313 DOUBLE TOM HOLDER

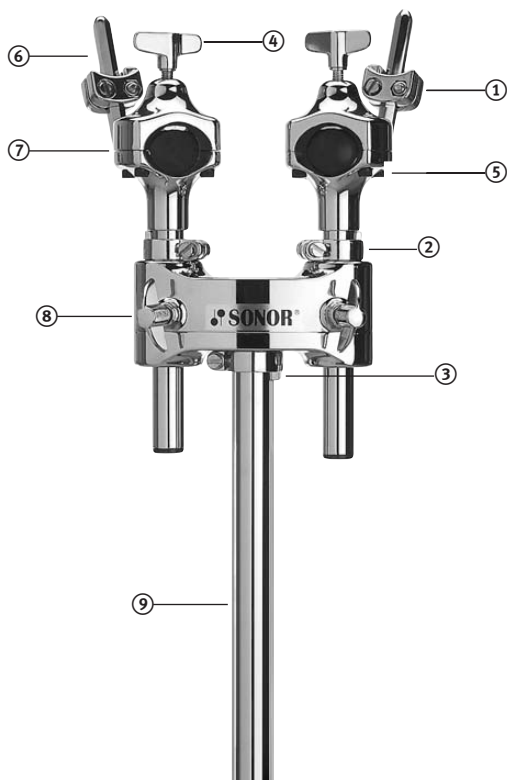
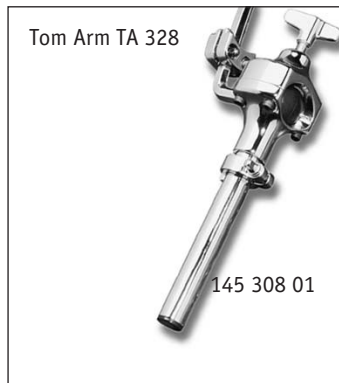
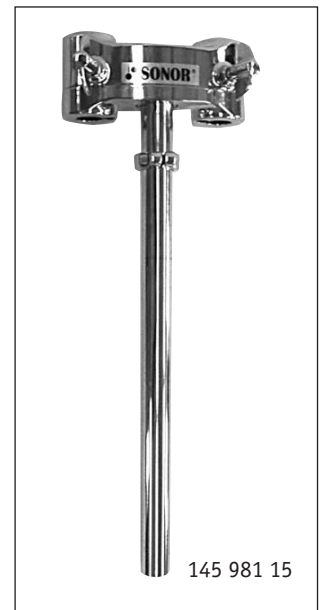
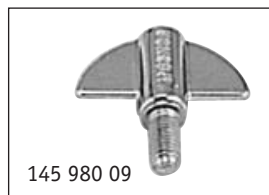

Item number	Description	Price
① 145 016 01	Memory Lock ML1, complete	<input type="text"/>
② 145 941 52	Fix Clamp, 19mm dia., complete	<input type="text"/>
③ 145 941 83	Fix Clamp, 25.5mm dia., complete	<input type="text"/>
④ 145 941 80	Wing Screw for Ball Socket Joint, M8 x 25, 2 pcs/pack	<input type="text"/>
⑤ 145 980 56	Allen Screw M5 x 20, DIN 912, with Washer, 4 sets/pack	<input type="text"/>
⑥ 145 980 55	Ball with Hex Arm and Memory Lock ML1, complete	<input type="text"/>
⑦ 145 308 01	Tom Arm TA 328, complete	<input type="text"/>
⑧ 145 980 09	Wing Screw M8 x 18, 3 pcs/pack	<input type="text"/>
⑨ 145 981 15	Tube with Bracket, complete	<input type="text"/>

200 SERIES HARDWARE

DT 211 DRUMMERS'S THRONE

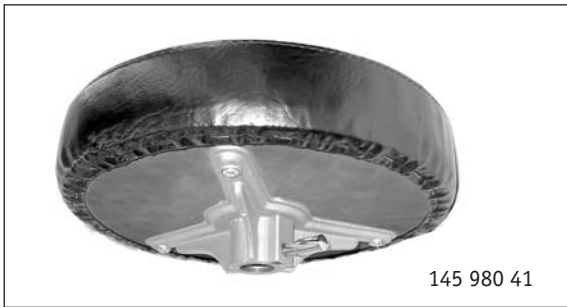

Item number	Description	Price
① 145 980 41	Seat Top	<input type="text"/>
② 145 980 52	Fix Clamp, complete, 2pcs/pack	<input type="text"/>
③ 145 980 09	Wing Screw M8 x 18, 3pcs/pack	<input type="text"/>
④ 145 980 43	Middle Tube, with Fix Clamp	<input type="text"/>
⑤ 145 980 05	Rubber Foot, 3 pcs/pack	<input type="text"/>

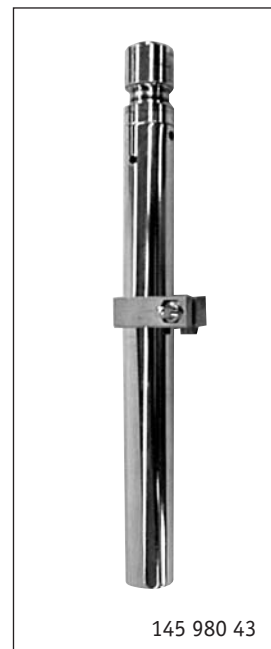

400 SERIES HARDWARE

MBA 441 MINI BOOM ARM

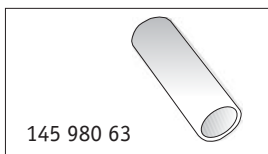
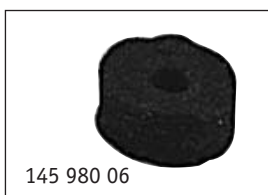

Item number	Description	Price
① 145 980 08	Top Cymbal Holder (Tilter), complete	<input type="text"/>
② 145 903 09	Wing Nut M8 with Washer, 3 pcs/pack	<input type="text"/>
③ 145 980 06	Felt Washer, 4 pcs/pack	<input type="text"/>
④ 145 980 63	Bushing, 6 pcs/pack	<input type="text"/>
⑤ 145 980 07	Metal Washer for Tilter, 35mm dia., 2 pcs/pack	<input type="text"/>
⑥ 145 980 51	Flat Round Screw M8 x 50 with Washer, Spring and Wing Nut, 2 pcs/pack	<input type="text"/>
⑦ 145 980 10	Extension Arm 16.5 x 300mm	<input type="text"/>
⑧ 145 980 11	Tube with Adjusting Lock, 19mm dia.	<input type="text"/>
⑨ 145 980 44	Wing Nut M6, 3 pcs/pack	<input type="text"/>

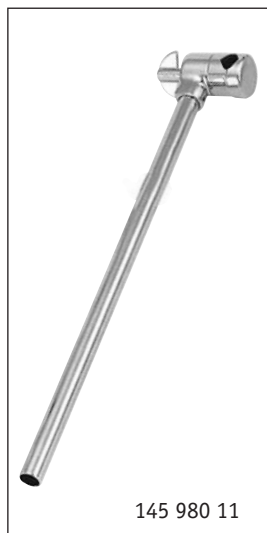
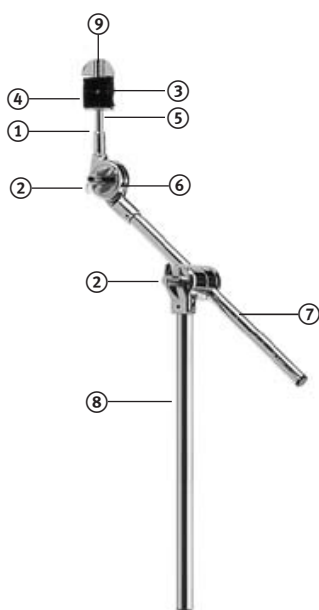

STH 3211 AX SINGLE TOM HOLDER

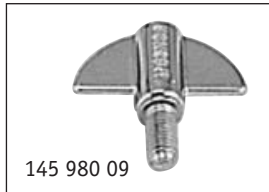
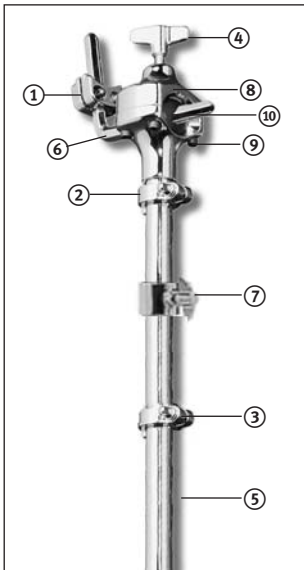

Item number	Description	Price
① 145 016 01	Memory Lock ML1, complete	<input type="text"/>
② 145 941 52	Fix Clamp, 19mm dia., complete	<input type="text"/>
③ 145 941 83	Fix Clamp, 25.5mm dia., complete	<input type="text"/>
④ 145 941 80	Wing Screw at Ball-on-Socket-Joint, M8 x 25, 2pcs/pack	<input type="text"/>
⑤ 145 980 53	Bottom Tube 25.5mm dia., with Fix Clamp, complete	<input type="text"/>
⑥ 145 980 54	Hex Arm and ML1, complete	<input type="text"/>
⑦ 145 980 09	Wing Screw M8 x 18, 3 pcs/pack	<input type="text"/>
⑧ 145 233 01	Tom Arm TA 3159 AX, complete	<input type="text"/>
⑨ 145 980 56	Allen Screw M5 x 20 DIN 912, with Washer, 4 pcs/pack	<input type="text"/>
⑩ 145 980 57	AX6-Ball, 2 pcs/pack	<input type="text"/>



FORCE SERIES

BASS DRUM HOOPS

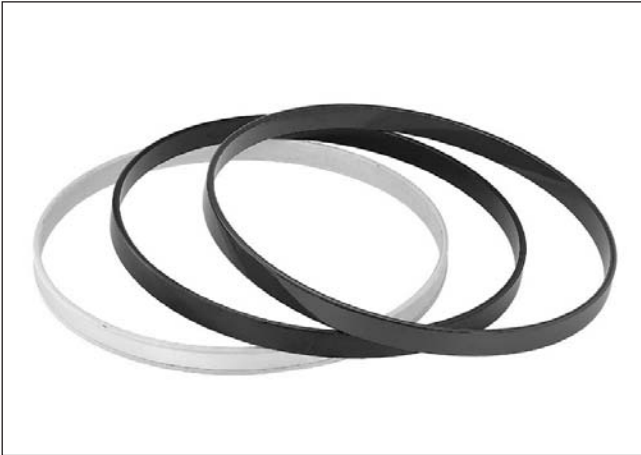

Item number	Description	Price
	FORCE 1001, 1003	
145 941 38	20", Reflex Silver	<input type="text"/>
145 941 39	20", Emerald Green	<input type="text"/>
145 941 40	20", Black	<input type="text"/>
145 941 41	20", Wine Red	<input type="text"/>
145 941 42	22", Reflex Silver	<input type="text"/>
145 941 43	22", Emerald Green	<input type="text"/>
145 941 44	22", Black	<input type="text"/>
145 941 45	22", Wine Red	<input type="text"/>
	FORCE 2001, 2003	
145 941 24	20", Wax Natural	<input type="text"/>
145 941 25	20", Midnight Black	<input type="text"/>
145 941 26	20", Cherry Red	<input type="text"/>
145 941 27	20", Stain Amber	<input type="text"/>
145 941 28	20", Diamond Blue	<input type="text"/>
145 941 31	22", Wax Natural	<input type="text"/>
145 941 32	22", Midnight Black	<input type="text"/>
145 941 33	22", Cherry Red	<input type="text"/>
145 941 34	22", Stain Amber	<input type="text"/>
145 941 35	22", Diamond Blue	<input type="text"/>
	FORCE 3001, 3003	
145 941 14	20", Purple	<input type="text"/>
145 941 15	20", Caribic	<input type="text"/>
145 941 16	20", White Sparkle	<input type="text"/>
145 941 17	20", BlackSparkle	<input type="text"/>
145 941 30	20", Honey Maple	<input type="text"/>
145 941 18	20", Piano Black	<input type="text"/>
145 941 29	20", Red Maple	<input type="text"/>
145 941 19	22", Purple	<input type="text"/>
145 941 20	22", Caribic	<input type="text"/>
145 941 21	20", White Sparkle	<input type="text"/>
145 941 22	22", BlackSparkle	<input type="text"/>
145 941 37	22", Honey Maple	<input type="text"/>
145 941 23	22", Piano Black	<input type="text"/>
145 941 36	22", Red Maple	<input type="text"/>

FORCE SERIES

BASS DRUMS



Item number	Description	Price
	BASS DRUM CLAW HOOK 1 PC/PACK	
145 941 61	FORCE 1001, 1003, 2001, 2003	<input type="text"/>
145 941 62	FORCE 3001, 3003	<input type="text"/>
	BASS DRUM TENSION ROD 3 PCS/PACK	
145 941 77	FORCE 1001, 1003, 2001, 2003, 3001, 3003	<input type="text"/>
	BASS DRUM LUG 1 PC/PACK	
145 941 54	FORCE 1001, 1003	<input type="text"/>
145 941 60	FORCE 2001, 2003, 3001, 3003	<input type="text"/>
	BASS DRUM BRACKET 1 PC/PACK	
145 903 04	FORCE 1001, 1003, 2001, 2003, 3001, 3003	<input type="text"/>
145 941 81	WING BOLT M8 x 40mm, 3PCS/PACK	<input type="text"/>
	BASS DRUM SPURS 1 PC/PACK	
145 941 63	Left Spur for FORCE 1001, 1003, 2001, 2003, 3001, 3003, with Memory Lock	<input type="text"/>
145 941 64	Right Spur for FORCE 1001, 1003, 2001, 2003, 3001, 3003, with Memory Lock	<input type="text"/>
	BASS DRUM/FLOOR TOM PRISM CLAMP, 1 PC/PACK	
145 941 56	FORCE 2001, 2003, 3001, 3003	<input type="text"/>
	WING NUT M8 FOR PRISM CLAMP, WITH WASHER, 3 PCS/PACK	
145 903 09	FORCE 1001, 1003, 2001, 2003, 3001, 3003	<input type="text"/>

FORCE SERIES

BASS DRUMS, TOMS, SNARE DRUMS

Item number	Description	Price
 145 903 10	 145 903 11	
	RUBBER TIP FOR BASS DRUM SPURS 3 PCS/PACK	<input type="text"/>
	145 903 10 FORCE 1001, 1003, 2001, 2003, 3001, 3003	
	KNURLED NUT FOR BASS DRUM SPURS, 3 PCS/PACK	<input type="text"/>
	145 903 11 FORCE 1001, 1003, 2001, 2003, 3001, 3003	
 145 941 78	 145 941 79	
	TENSION ROD, 6 PC/PACK 7/32" x 45mm, FORCE 1001, 1003, Steel Snare Drums, Tom Toms, Floor Toms	<input type="text"/>
	145 941 79 7/32" x 55mm, FORCE 2001, 2003, 3001, 3003, Snare Drum, Tom Toms, Floor Toms	<input type="text"/>
 145 941 53	 145 941 58	
	145 941 04 TENSION ROD FOR JUNGLE SNARE, COMPLETE, 6 PCS/PACK (not illustrated)	<input type="text"/>
	TENSION LUG, 1 PC/PACK, WITH ASSEMBLY SCREWS	<input type="text"/>
	145 941 53 FORCE 1001, 1003	<input type="text"/>
	145 941 58 FORCE 2001, 2003, 3001, 3003	<input type="text"/>
 145 941 57	 145 941 68 145 980 74	
	TOM TOM BRACKET 1 PC/PACK	<input type="text"/>
	145 941 57 FORCE 1001, 1003, 2001, 2003, 3001, 3003	
 145 941 56 please see page 22	 145 941 65 145 941 67	
	LEGS FOR FLOOR TOMS 1 PC/PACK	<input type="text"/>
	145 941 68 FORCE 1001, 1003	<input type="text"/>
	145 980 74 WING SCREW M8 x 30, 3 pcs/pack	<input type="text"/>
	FLOOR TOM LEG, 1 PC/PACK	<input type="text"/>
	145 941 67 FORCE 1001, 1003	<input type="text"/>
	145 941 76 Rubber Tip, 3 pcs/pack	<input type="text"/>
	145 941 65 FORCE 2001, 2003, 3001, 3003	<input type="text"/>
	145 980 76 Rubber Tip, 3 pcs/pack	<input type="text"/>

FORCE SERIES

SNARE DRUMS

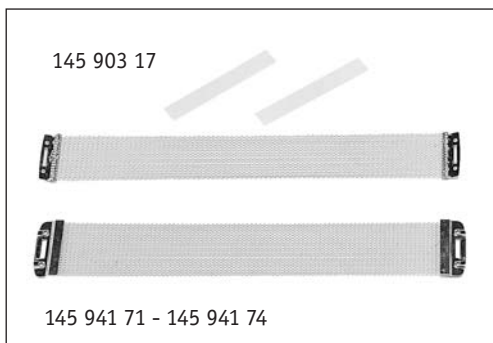
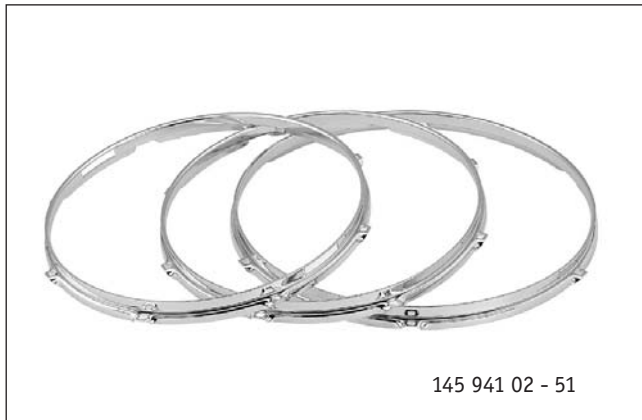

Item number	Description	Price
	SNARE DRUM TENSION HOOPS	
	1 PC/PACK	
145 941 08	14", 8 Lugs, 1.6mm Top Hoop for Force 1001, 1003, 2001, 2003	<input type="text"/>
145 941 50	14", 10 Lugs, 2.3mm Top Hoop for Force 3001, 3003	<input type="text"/>
145 941 46	10", 6 Lugs, 2.3mm Top Hoop, for Wood Snare Drum	<input type="text"/>
145 941 02	10", 6 Lugs, 1.6mm, Top Hoop for Jungle Snare	<input type="text"/>
145 941 48	12", 6 Lugs, 2.3mm Top Hoop, for Wood Snare Drum	<input type="text"/>
145 941 10	14", 8 Lugs, 1.6mm Bottom Hoop for Force 1001, 1003, 2001, 2003	<input type="text"/>
145 941 51	14", 10 Lugs, 2.3mm Bottom Hoop for Force 3001, 3003	<input type="text"/>
145 941 47	10", 6 Lugs, 2.3mm Bottom Hoop for Wood Snare Drums	<input type="text"/>
145 941 49	12", 6 Lugs, 2.3mm Bottom Hoop for Wood Snare Drums	<input type="text"/>
	SNARE DRUM TENSION LUGS	
	1 PC/PACK, W/ ASSEMBLY SCREWS	
145 941 55	For Force 1001, 1003	<input type="text"/>
145 941 59	For Force 2001, 2003, 3001, 3003	<input type="text"/>
	SNARE DRUM STRAINER	
	1 SET/PACK	
145 941 70	Snare Strainer & Snare Butt	<input type="text"/>
	SNARE STRANDS AND STRAPS	
145 941 74	16 Wire Snares 14", 1 pc/pack for Force 1001, 1003, 2001, 2003	<input type="text"/>
145 941 71	20 Wire Snares 14", 1 pc/pack for Force 3001, 3003	<input type="text"/>
145 941 82	12 Wire Snares 10", 1 pc/pack for Jungle Snare Drums	<input type="text"/>
145 941 73	16 Wire Snares 10", 1 pc/pack	<input type="text"/>
145 941 72	16 Wire Snares 12", 1 pc/pack	<input type="text"/>
145 903 17	Strap for Snares, 3 pcs/pack	<input type="text"/>

FORCE SERIES

MISCELLANEOUS

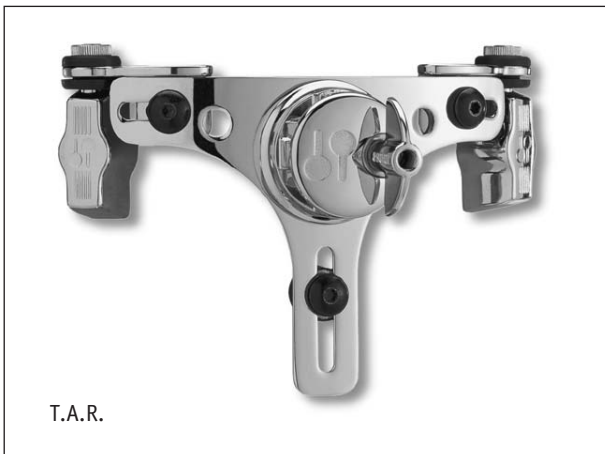
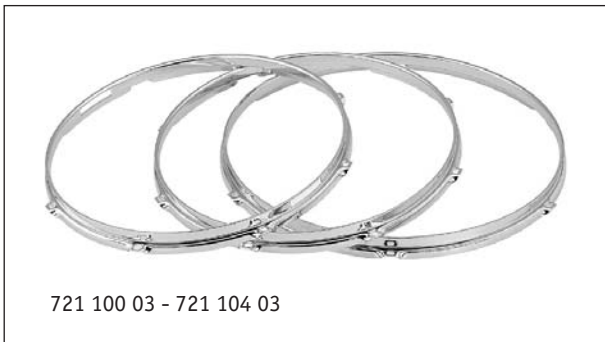

Item number	Description	Price
	DRUM BADGES	
	4 PCS/PACK	
145 901 12	Force 1003 Badge	<input type="text"/>
145 902 12	Force 2003 Badge	<input type="text"/>
145 903 12	Force 3003 Badge	<input type="text"/>
145 903 18	Jungle Badge	<input type="text"/>
	TOM HOOPS	
	1 PC/PACK	
145 941 05	10", 5 Rods, 1.6 mm	<input type="text"/>
145 941 06	12", 6 Rods, 1.6 mm	<input type="text"/>
145 941 07	13", 6 Rods, 1.6 mm	<input type="text"/>
145 941 12	14", 6 Rods, 1.6 mm	<input type="text"/>
145 941 13	16", 6 Rods, 1.6 mm	<input type="text"/>
145 941 11	8", 4 Rods, 1.6 mm	<input type="text"/>
145 941 08	14", 8 Rods, 1.6 mm	<input type="text"/>
145 941 09	16", 8 Rods, 1.6 mm	<input type="text"/>
	T.A.R. UPGRADE KITS	
	1 SET/PACK	
145 314 01	T.A.R. 0813 for 8" - 13" Force 2001 and 3001 Tom Toms	<input type="text"/>
145 315 01	T.A.R. 1416 for 14" - 16" Force 3001 Tom Toms	<input type="text"/>
145 316 01	T.A.R. 14-6 for 14" Force 2001 Tom Tom only	<input type="text"/>
	SONOR MULTI KEY	
190 072 01	Sonor Multi Key	<input type="text"/>